

KELCO

F60 MK3 Pump Controller

SIMPLE TO USE AND VERY POWERFUL
THE ULTIMATE IN VERSATILE & FLEXIBLE PUMP CONTROL

Features

- Very simple to program
- Multi voltage operation
- Displays pressure and set points
- 15 Programmable timers built in
- Powerful 40 Amp solid state drive
- Dedicated alarm relay
- Detachable electrical housing
- 20 Bar 290 psi Pressure rating
- Suits pipes 25mm (1") & Larger
- Accepts remote input
- Weatherproof Housing



The F60 MK3 Digital Pump Controllers monitor system pressure and flow to ensure complete pump protection. It can be set to control a single or dual pump system, with a wide range of functions.

Further information including installation guides, programming guides and videos can be found on our website:
<https://www.kelco.com.au/f60-mk3-advanced-pump-controller/>

3-Phase Pump Motors

The F60 MK3 can be used to control both single and 3-phase pumps provided a 220~240 VAC or 24VAC supply is available at the installation site.

Ordering

The F60 MK3 Digital Pump Controller is available in all thermoplastic construction with a 1" BSP process connection. The standard controller can operate from 220 ~ 240 VAC or from 24 VAC or DC. A dedicated 12 VDC model is also available.

Model Number	Description
F60 MK3	Standard model for 220 ~ 240 VAC and 24V AC or 24V DC operation.
F60-12-MK3	Low voltage model for 12V DC operation only.

F60 SERIES DATA

Dimensions

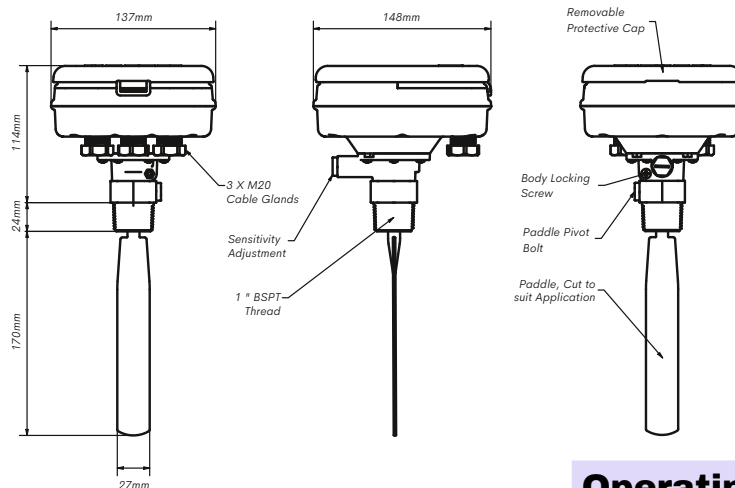

Operating Limitations

Functions

The F60 MK3 includes 5 unique operating modes each with a wide range of options. The table below sets out the functions and the modes they operate under.

MODES OF OPERATION	1	2	3	4	5
Functions (# Settable)					
# Select pressure units kPa or psi	Y	Y	Y	Y	Y
# Pre-start delay timer.	Y	Y	Y	Y	Y
# Start-up timer	Y	Y	Y	Y	Y
# Pressure Timer (Allows time for the pressure to rise)				Y	
# Run-on timer	Y	Y	Y	Y	Y
# Pressure dip timer				Y	Y
# Delayed restarting timer	Y	Y	Y	Y	Y
# Starting pressure		Y	Y	Y	Y
# Stopping pressure			Y	Y	Y
# Cyclic running and stopping timers	Y	Y		Y	
# Auto restart if run dry. Single or repeatable tries		Y	Y	Y	
# Anti-cycling	Y	Y	Y		
# Burst pipe detection	Y	Y	Y		
# Leak detector			Y		
# Dual pump control with or without dual flow sensing					Y
# Starts the pump at a preset low pressure		Y	Y		Y
# Stops the pump at a preset high pressure			Y	Y	Y
Stops the pump if flow stops	Y	Y	Y	Y	Y
Displays the system pressure in preferred units	Y	Y	Y	Y	Y
Displays the high & low pressure set points			Y	Y	
Can start the pump using an external switch	Y	Y	Y	Y	Y
Starts & stops the pump on flow regardless of pressure	Y				
Displays the total time the pump ran in minutes				Y	
On a fault, displays the reason the pump was shut down	Y	Y	Y	Y	Y
Remote stop via an external switch opening its contacts	Y	Y	Y	Y	Y
Stops the pump if flow stops.	Y	Y	Y	Y	Y
Loss of prime protection for the pump(s).	Y	Y	Y	Y	Y

Serviceability

The F60 MK3 digital pump controller is not user serviceable. However, spare parts are available from Kelco Engineering or from your distributor.

Operating Range	
Ambient Temperature Range	1°C to 50°C
Liquid Temperature Range	1°C to 60°C
Ingress Protection Rating	IP64
Pre-Start Delay Timer (In all modes)	Adjustable from 1 second to 18 hours in 1 second increments
Start-Up Timer (In all modes)	Adjustable from 1 second to 15 minutes in 1 second increments
Pressure Rise Timer (In Mode 4 only)	Adjustable from 1 second to 15 minutes in 1 second increments
Run-On Timer (In all modes)	Adjustable from 1 second to 15 minutes in 1 second increments
Pressure Dip Timer (In modes 4 only)	Adjustable from 1 second to 4 minutes in 1 second increments
Delayed Restarting (In modes 1 to 3 only)	Adjustable from 1 minute to 99 hours 59 minutes in 1 minute increments
Cyclic Running & Stopping (In all modes)	Running and stopping times both adjustable from 2 minutes to 99 hours 59 minutes in 1 minute increments
Auto Restart if Run Dry (In all modes)	Adjustable from 1 minute to 99 hours 59 minutes in 1 minute increments
Anti Cycling (In modes 1 to 3 only)	Adjustable from 1 motor start per hour to 1800 motor starts per hour
Burst Pipe Detector (In mode 3 only)	Adjustable from 1 minute to 99 hours 59 minutes in 1 minute increments
Maximum Operating Pressure Static or Dynamic	20 Bars 290 psi
Minimum Burst Pressure	> 25 Bars 360 psi
Starting Pressure Range	0 to 2000 kPa or 0 to 290 psi in steps of 1 kPa or 1 psi
Stopping Pressure Range	0 to 2000 kPa or 0 to 290 psi in steps of 1 kPa or 1 psi
Minimum Pressure Differential On to Off, and Off to On	1 kPa or 1 psi
Recommended Pipe Size	25 mm 1" or larger. (There is no upper limit)

Electrical Data

Supply voltage (Standard model)	220 to 250 VAC or 18 to 25 VAC or DC (Multi Voltage Input)
Supply voltage (12VDC model)	11 to 14 VDC - 65mA Current Draw
Maximum motor load (all models)	Single phase motors up to 2.4kW maximum at 240VAC (P1) 3-phase motors of all sizes via a suitable interposing contactor, no maximum motor size applies when using an interposing contactor
Relay 1 Normally Open contact rating when HD terminal is NOT used	10 Amps at 240 VAC resistive
Relay 1 Normally Closed contact rating	3.5 Amps at 240 VAC resistive
Relay 2 Normally Open contacts	3.5 Amps at 240 VAC resistive

Kelco Engineering Pty Ltd

ABN 20 002 834 844

Head Office & Factory
9/9 Powells Road,
Brookvale 2100 NSW Australia

Postal Address
PO Box 7485 Warringah Mall
Brookvale 2100 NSW Australia

Phone: +61 2 99056425
Fax: +61 2 9905 6420

Email: Sales@kelco.com.au
Web: www.Kelco.com.au

PLEASE NOTE: Kelco Engineering Pty Ltd reserves the right to change the specification of this product without notice. Users will use their own judgment to determine the appropriateness of using Kelco Products in an application, any safety measures required and that the product is properly installed for that application. To the extent permitted by law Kelco Engineering Pty Ltd disclaims and excludes all and any liability for the use of this product in any particular application or for defective installation. Kelco switches are warranted against malfunction by a 12 month return to base manufacturer's warranty. Full details of our warranty and limitation of liability can be found in this document or downloaded from: <http://www.kelco.com.au/warranty>

All rights reserved copyright Kelco Engineering Pty Ltd © 2022